

Indian Institute of Science

CCE: Neural Networks for Signal Processing-1

Instructor: Shayan Srinivasa Garani.

TA: Prayag Gowgi.

Home Work #1, Spring 2017

Late submission policy: Points scored = Correct points scored $\times e^{-d}$, $d = \#$ days late

Assigned date: Jan 20th 2017

Due date: Feb 3rd 2017 in class

PROBLEM 1: Understand supervised, unsupervised and reinforced learning mechanisms (refer to any material). Which learning mechanism would you suggest in the following scenarios?

- (a) Imagine yourself working for Flipkart or Amazon and you would like to recommend a book to a user.
- (b) You would like to develop an android based game, say chess.
- (c) You are interested in learning to play guitar.
- (d) You are developing an application for a bank that decides whether to give a loan or not to a customer.

(8 pts.)

PROBLEM 2: We humans tend to forget events with time unless it is reinforced again and again. There are exceptional individuals who can remember almost every event. Let us ignore such cases for a moment. Memory can be modeled using a feedback loop within a neural network architecture. Forgetting events in humans can be modeled as a reduction in the feedback strength with time. Justify the statement mathematically for a single neuron case.

Hint: In the class, we learned signal flow graphs of a single-loop feedback system.

(3 pts.)

PROBLEM 3: In the class, we learned that biological neurons are slower compared to artificial neurons. However, we are able to do more complex tasks in lesser time compared to artificial neuron based systems. What do you think is the reason behind this? (Imagine that you are given the same number of biological and artificial neurons using Silicon gates.)

(4 pts.)

PROBLEM 4: Consider the sigmoid activation function. The parameter a is called the slope parameter.

$$\phi(v) = \frac{1}{1 + \exp(-av + b)} \quad (1)$$

- (a) With $b = 0$, plot the sigmoid activation function for different values of a (for $a = 0, 1, 10, 100, 200$).
- (b) With $a = 1$, plot sigmoid activation function for different values of bias $b = -10, 0, 10$. What is the role of bias in the neuronal model?

(4 pts.)

PROBLEM 5: An odd sigmoid function is defined by

$$\phi(v) = \frac{1 - \exp(-av)}{1 + \exp(-av)} = \tanh\left(\frac{av}{2}\right), \quad (2)$$

where $\tanh(\cdot)$ is the hyperbolic tangent function. Show that the derivative of $\phi(v)$ with respect to v is given by

$$\frac{d\phi}{dv} = \frac{a}{2} (1 - \phi^2(v)). \quad (3)$$

What is the value of this derivative at the origin? Suppose that the slope parameter a is made ∞ . What is the resulting form of $\phi(v)$? (4 pts.)

PROBLEM 6: Understand the cumulative distribution function (CDF) (refer to any material). Which of the following sigmoid functions qualifies as a cumulative distribution function? Justify your answer.

$$\phi(v) = \frac{1}{1 + \exp(-av)} \quad (4)$$

$$\phi(v) = \frac{1 - \exp(-av)}{1 + \exp(-av)} \quad (5)$$

$$\phi(v) = \frac{v}{\sqrt{1 + v^2}} \quad (6)$$

$$\phi(v) = \frac{1}{\sqrt{2\pi}} \int_{-\infty}^v \exp\left(-\frac{x^2}{2}\right) dx \quad (7)$$

$$\phi(v) = \frac{2}{\pi} \arctan(v) \quad (8)$$

(6 pts.)

PROBLEM 7: In the class, we learned the model of an artificial neuron as shown in Figure 1.

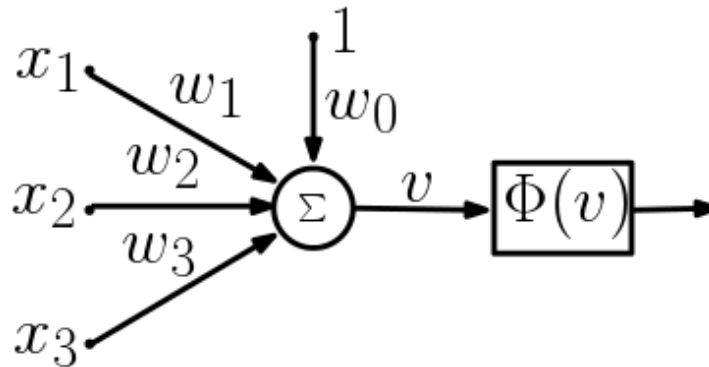

FIGURE 1. Artificial neuron model

- (a) The probability of a stochastic neuron firing is given by

$$P(v) = \frac{K}{1 + \exp\left(-\frac{v}{T}\right)}, \quad (9)$$

where $T \in [0, \infty]$ is a control parameter, K is a constant (refer to your class notes). For what value of K , is $\phi(v)$ a valid probability density function (pdf)?

- (b) Using the neuronal model in question 7 (refer Figure 1), come up with a feed forward neural network architecture with two neurons. (Use any drawing tool to draw the architecture). Write down the equations at each and every point in the network.
- (c) Assuming the stochastic neuron model as given in question 7(a) in your feed forward architecture, write down the equations at each and every point within your architecture.
- (d) With the stochastic neuron model as given in question 7(a), come up with a recurrent neural network architecture with no self feedback loops on each neuron. Write all the equations at each and every point in your architecture.
- (e) In the class, we learned that the output of a stochastic neuron is binary i.e.,

$$X = \begin{cases} +1, & \text{with probability } P(v) \\ -1, & \text{with probability } 1 - P(v). \end{cases} \quad (10)$$

If you require the output of a stochastic neuron to be continuous rather than binary, for some application. How would you modify your neuron model?

(21 pts.)